

REF	PART	DESCRIPTION	REF	PART	DESCRIPTION	REF	PART	DESCRIPTION
1	13-1110	Stand Upright	8		Screw #8 Hex Head Slotted	17	13-1010	Grill Guard
2	13-1120	Stand Upright (Crimped)	14-2550		SRS-C Set of Casters	18	13-1690	HT Power Cord
3	13-1102	Stand Base Crossbar	9	14-1691	Cross Arm Assembly	13-1080		Speedray HT Hardware Set
4	13-1100	Stand Leg (left)	10	13-1090	1/4-20 x 9/16" Male Knob	13-1700		HT Cross Arm Assm. w/ Heater
4	13-1101	Stand Leg (right)	11,12	13-1095	Tab Washer w/ Female Knob	13-1030		Reflector
5		Stand Frame Bolt 3/8-16 x 3/4"	13	13-1680	End Reflector	13-1050		Junction Box w/ Power Cord
6	13-1130	Caster (ea.)	14		End Reflector Fastener #6 Screw	13-1070		Lead Wire Set
	13-1140	Stand Hardware Set	15	10-3080	E-2012-SR Element (120V 32")	13-1460		60 Min. Timer F-60-M
7		Upright Fasteners 5/16-8x11/2"	16		Element Fastener 8-32" Hex Nut	13-1600		1/4-20 x 9/16" Black Male Knob

## ASSEMBLING YOUR NEW SYSTEM

**Unpack Your System:** Carefully unpack your new system, making sure all parts for assembly are included. If any parts are missing, call customer service for replacement.

**Assemble Stand:** Install casters (6) and end caps first, then slide together legs (4) and crossbar (3). Bolt H-frame parts together with supplied 3/8" bolts (5). Assemble upright by sliding crimped (2) and uncrimped (1) sections together and inserting lock screw (8). With the stand sitting upright on its casters, insert upright and secure with supplied 5/16" fasteners (7).

**Install Element:** Lay heater housing face up on a stable work surface. Remove end reflectors. Remove grill guard by grasping center cross wire on guard, and with other hand, place thumb close to the grill's mounting hole. Gently press reflector away with your thumb while removing guard center wire from hole. Remove center wire from bottom. Remove guard by sliding left then right. Carefully unpack element (note: it's made with quartz glass and can easily be broken). Remove one nut from the ends of element; slip ring terminals over studs and replace nuts. NOTE: Hold element ceramic firmly while

tightening nuts (use two wrenches). Nuts should be snugly tightened; loose ring connections may damage the element. Place element in U-channel and reinstall end reflectors and grill.

**Final Assembly:** Attach locking knob to rotator cross arm, then assembly to heater housing with supplied tab washer and knob. Install vertical slid locking knob to cross arm and slide assembly onto upright post on stand; secure at desired position with locking knob.

**First Use:** Your Infratech curing system is ready for use. Only plug into a grounded power source. Position the system 18" or more away from the area to be cured.

### WARNINGS:

- Source of possible ignition**
- NEVER block front of heater**
- DO NOT operate within 25' of flammable materials**
- DANGER: to reduce risk of explosion do not use within 10' of spraying operations while spraying**
- NEVER service heater without disconnecting from power**
- Source of possible shock**
- Use only with grounded power source**

## OPERATING TIPS

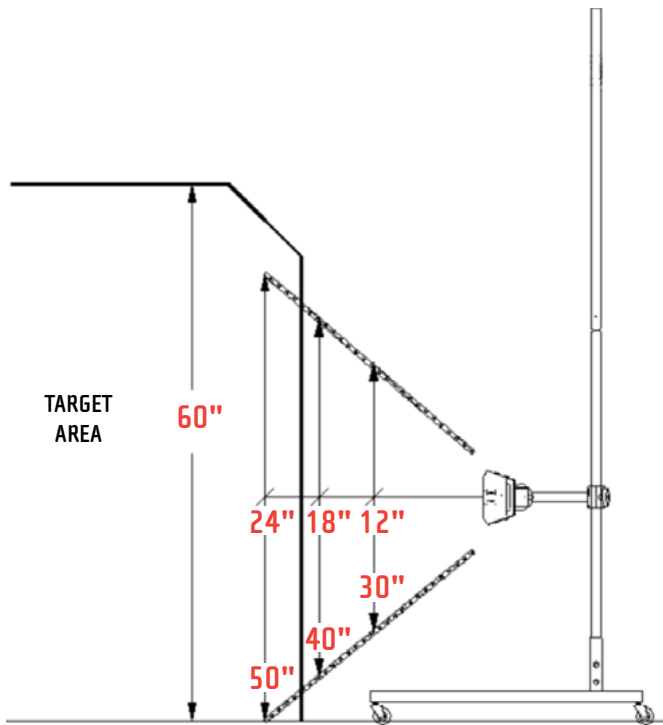

Your new Infratech infrared (IR) curing system provides fast, efficient curing for virtually every type of paint, primer, body filler, bonding adhesive and plastic repair product. Infratech infrared heats from the inside out, providing the best possible cure. It does not heat the air. IR cures fast by heating the coating and panel for the prescribed time to effect solvent evacuating and cross linking; the cure cycle is complete after the heated area cools back to room temperature. Once this full cycle is complete, the coating is fully cured and final assembly or cleanup for delivery can start. Care should be taken when using your new system. Operating the system too close to the part being cured can cause damage. When you first use your system, start at a distance of 24" to 30". As you gain experience using your system, you may be able to move the system closer (18" min. distance) to apply more heat and speed the curing cycle. Infratech heaters are powerful enough to blister paint and melt plastic. Additionally, it should be noted that different colors absorb IR at different rates; black absorbs IR far quicker than white. So darker colors may cure faster than lighter colors. Adjustments in distance may have to be made to accommodate the differences.

## CURING TIME

ITEM	DISTANCE FROM SURFACE	COVERAGE (H x W)	CURING TIME
2 K Primers	18"	3' x 4'	5-10 minutes
Waterborne Base Coat	18"	3' x 4'	5-6 minutes
Filler/Stoppers	18"	3' x 4'	10-12 minutes
Plastic Body Fillers	18"	3' x 4'	10-15 minutes
2K Plastic Repair	18"	3' x 4'	10-15 minutes
Acrylic Enamels	18"-30"	3' x 4'	15-20 minutes
2 K Top Coats	18"-30"	3' x 4'	10-15 minutes
High Build Primers	18"	3' x 4'	15-20 minutes
Structural Adhesives	18"	3' x 4'	15-20 minutes
Polyurethane	18"-30"	3' x 4'	18-25 minutes
Synthetic Enamels	18"-30"	3' x 4'	15-20 minutes
High Solids Clear	18"-30"	3' x 4'	12-18 minutes

## SPECIFICATIONS

PART NUMBER	MODEL	LENGTH	WATTS	VOLTS	AMPS	SHIPPING WEIGHT (LBS)
16-1000	SRU-1615HT	36"	2,000	120	17	24

**Need help?** To order replacement elements for your Infratech heating system, please contact us via phone or visit the automotive section of our website.